

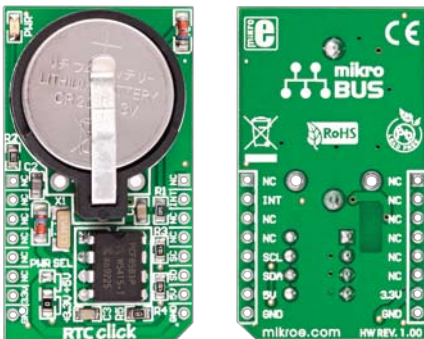

RTC click

1. Introduction



RTC Click is an accessory board in **mikroBus™** form factor. It features the **PCF8583P** serial real-time clock (RTC). It is a low-power, full binary-coded decimal (BCD) clock/calendar. Board uses I²C interface for communication and features a 3V/230mA **lithium battery** as a backup power supply which ensures that timekeeping operation continues even when the main power supply goes OFF. Board is set to use 3.3V power supply by default. Solder **PWR SEL** SMD jumper to 5V position if used with 5V systems.

2. Soldering the headers

Before using your click board, make sure to solder the provided 1x8 male headers to both sides of the board. Please locate the headers in the top side of the inner box of the board package, and take them out.

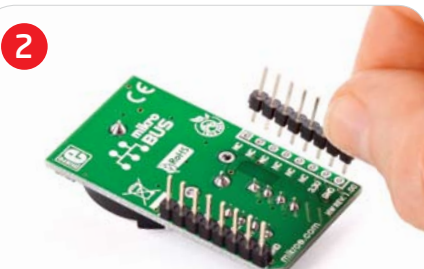

Turn the board upside down, so that bottom side is facing you upwards. Place shorter parts of the header pins in the both soldering pad locations.



Turn the board upward again. Make sure to align the headers so that they are perpendicular to the board, then solder the pins carefully.



4. Board applications

RTC click is ideal for applications which require real-time clocks, calendars and programmed alarms. Communication with the board is done over standard I²C interface. The Real-Time Clock (RTC) has 24 hour or 12 hour format, it has programmable alarm, timer, and interrupt function.

3. Plugging the board in

Once you have soldered the headers your board is ready to be placed into desired mikroBUS™ socket. Make sure to align the cut in the lower-right part of the board with the markings on the silkscreen at the mikroBUS™ socket. If all the pins are aligned correctly, push the board all the way into the socket.

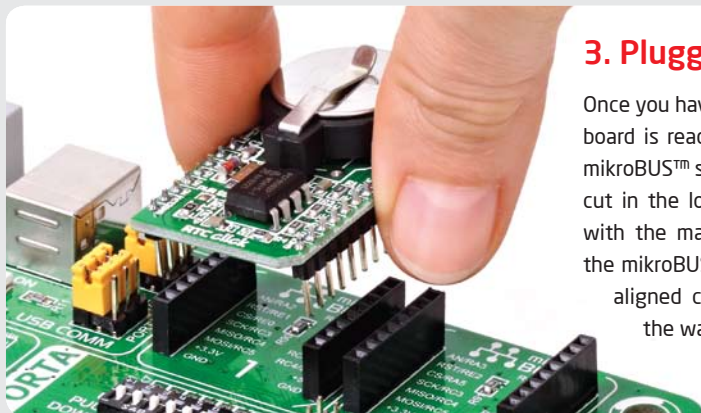

click
BOARD
www.mikroe.com



5. RTC click Board Schematics

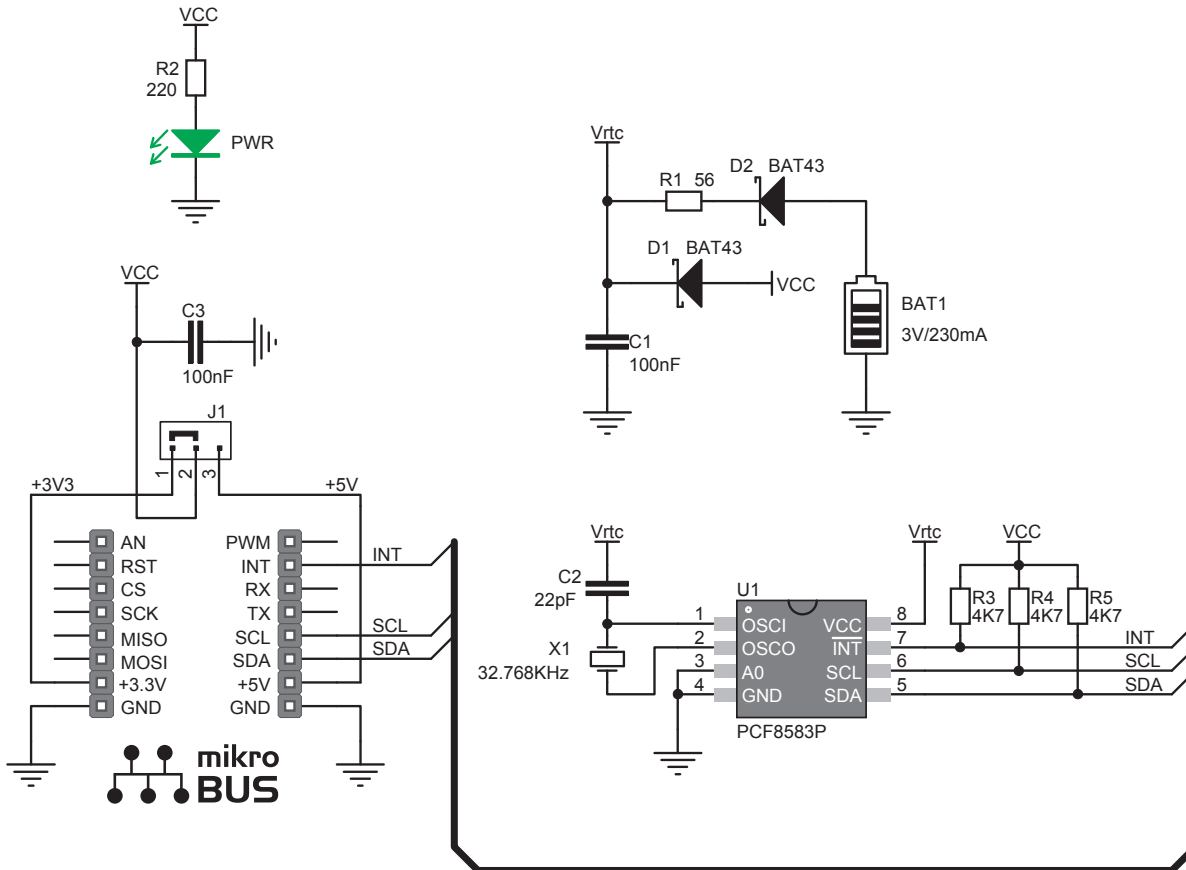

6. Power supply selection



On-board **PWR SEL** zero-ohm resistor (SMD jumper) is used to determine whether 5V or 3.3V power supply is used. This resistor is provided in 3.3V position by default. In order to use RTC click with 5V development system, it is necessary to resolder this jumper to 5V position.

7. Code Examples

Once you have done all the necessary preparations, it's time to get your click board up and running. We have provided the examples for mikroC, mikroBasic and mikroPascal compilers on our **Libstock** website. Just download them and you are ready to start.



8. Support

MikroElektronika offers **Free Tech Support** (www.mikroe.com/esupport) until the end of product lifetime, so if something goes wrong, we are ready and willing to help!