

mikroBUS™ pinout standard specification

What is mikroBUS™?

As we in mikroElektronika see it, plug-and-play devices with minimum settings are the future in embedded world. This is why our engineers have come up with a simple but brilliant pinout with lines that most of today's accessory boards require, which almost completely eliminates the need of additional hardware settings. We called this new standard the **mikroBUS™**.

mikroBUS™ host connector

Each **mikroBUS™** host connector consists of two 1x8 female headers containing pins that are most likely to be used in the target accessory board. There are three groups of communication pins: **SPI**, **UART** and **I²C** communication. There are also single pins for **PWM**, **Interrupt**, **Analog input**, **Reset** and **Chip Select**. Pinout contains two power groups: **+5V** and **GND** on one header and **+3.3V** and **GND** on the other 1x8 header. **mikroBUS™** host connector perfectly fits into standard breadboards.

Integration in your designs

mikroBUS™ is not made to be only a part of our development boards. You can freely place **mikroBUS™** host connectors in your final PCB designs, as long as you clearly mark them on the silkscreen with **mikroBUS™** footprint specifications which can be downloaded from the following link:
http://www.mikroe.com/download/mikrobus_specs.zip

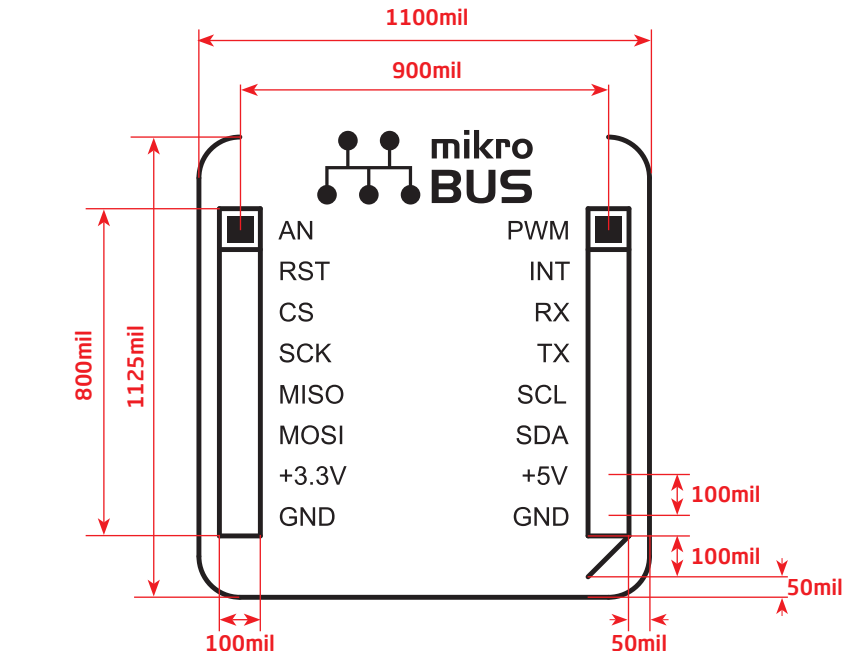

AN - Analog pin
RST - Reset pin
CS - SPI Chip Select line
SCK - SPI Clock line
MISO - SPI Slave Output line
MOSI - SPI Slave Input line
+3.3V - VCC-3.3V power line
GND - Reference Ground

PWM - PWM output line
INT - Hardware Interrupt line
RX - UART Receive line
TX - UART Transmit line
SCL - I²C Clock line
SDA - I²C Data line
+5V - VCC-5V power line
GND - Reference Ground

Click boards™ are plug-n-play

mikroElektronika's portfolio of almost 200 accessory boards is now enriched by an additional set of **mikroBUS™** compatible **Click boards™**. It is our intention to provide the community with as much of these boards as possible, so you will be able to expand your designs with additional functionality and minimum hardware configuration. Just plug and play.

Can I make mikroBUS™ boards?

You are allowed to produce your own **mikroBUS™** compatible board, as long as you place **mikroBUS™** logo on the board silkscreen. Also, you are not allowed to call it "Click board" because "Click" is the trademark of mikroElektronika. If you want to make commercial version of your board, you are obliged to inform us about it at office@mikroe.com

Copyright © mikroElektronika, December 2011. All rights reserved.

