



# DAC click

## 1. Introduction



Front and back side appearance of the DAC click Board

DAC Click is an accessory board in **mikroBus™** form factor. It includes a 12-bit Digital-to-Analog Converter **MCP4921** that features SPI interface and an optional double buffered output. The board provides high accuracy and low noise performance for industrial applications where calibration or compensation of signals, such as temperature, pressure and humidity, are required. Board is set to use 3.3V power supply by default. Solder **PWR SEL** SMD jumper to 5V position if used with 5V systems.

## 2. Soldering the headers

Before using your click board, make sure to solder the provided 1x8 male headers to both sides of the board. Please locate the headers in the top side of the inner box of the board package, and take them out.

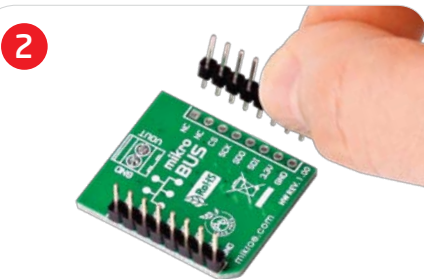

Turn the board upside down, so that bottom side is facing you upwards. Place shorter parts of the header pins in the both soldering pad locations.

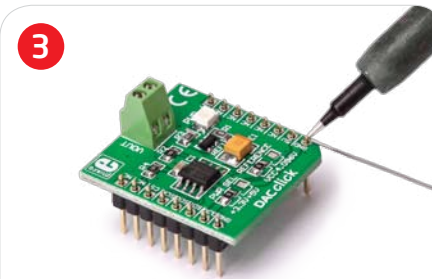

Turn the board upward again. Make sure to align the headers so that they are perpendicular to the board, then solder the pins carefully.

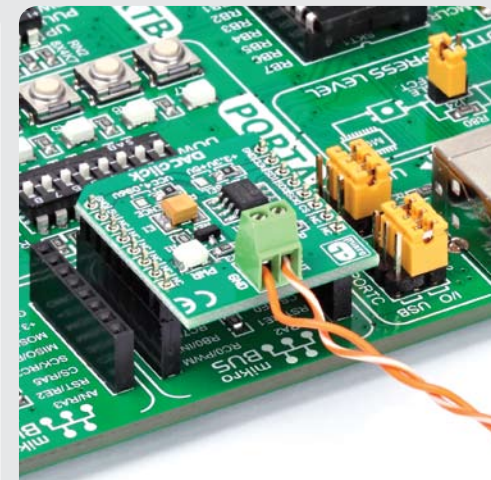

## 4. Creating Output Voltages

Board contains two analog output screw terminals: **Vout** and **GND**. Data in 12-bit format is sent to the DAC using SPI communication interface. This data is converted to the appropriate voltage level in the range between GND and **REFERENCE** (VCC or 4.096V), which is proportional to the received 12-bit number.

## 3. Plugging the board in

Once you have soldered the headers your board is ready to be placed into desired mikroBUS™ socket. Make sure to align the cut in the lower-right part of the board with the markings on the silkscreen at the mikroBUS™ socket. If all the pins are aligned correctly, push the board all the way into the socket.

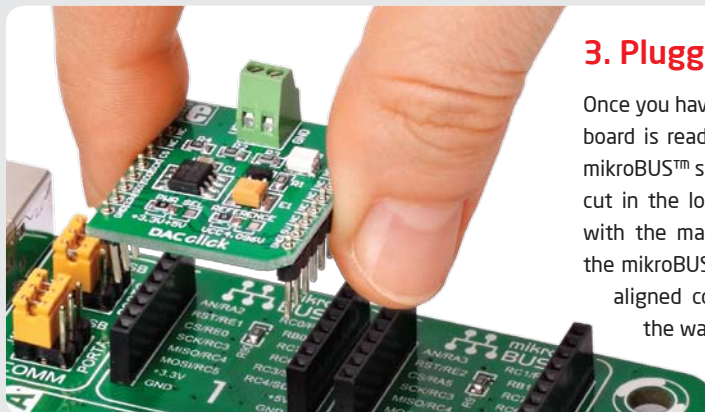

**click**  
**BOARD**  
[www.mikroe.com](http://www.mikroe.com)

## 5. DAC click Board Schematics

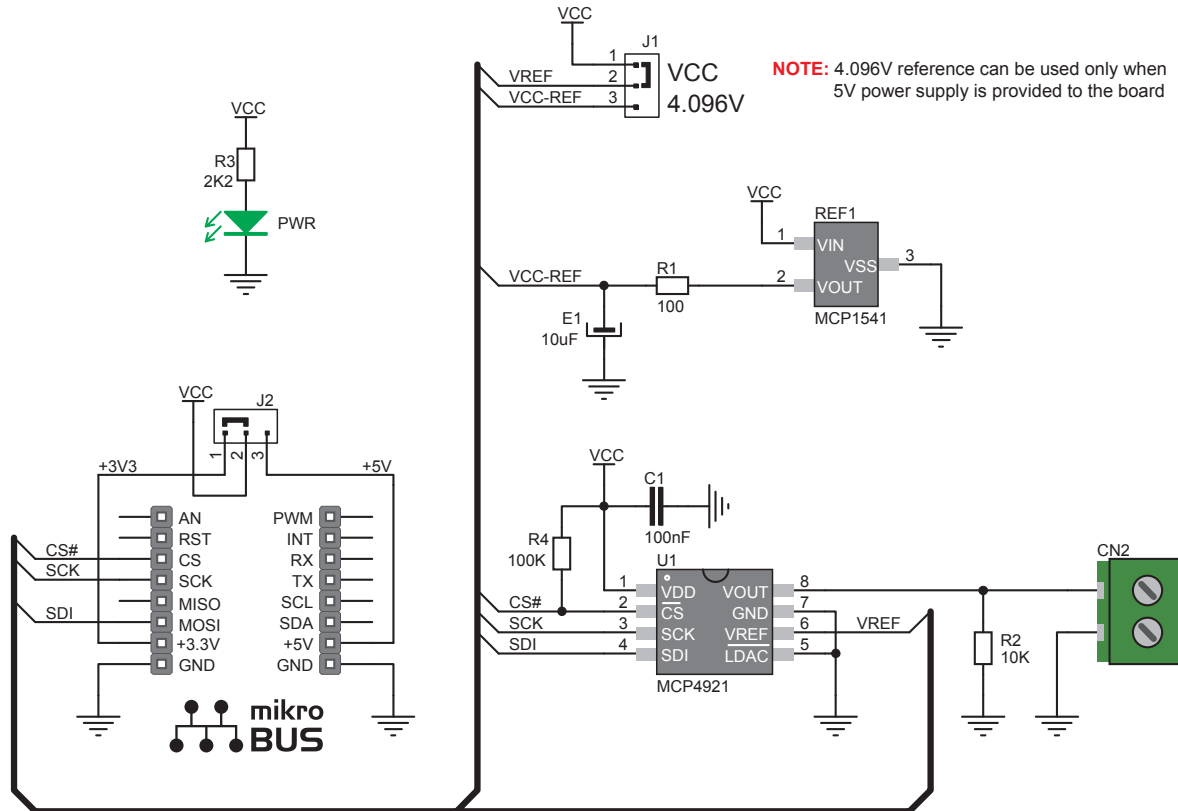

## 6. SMD Jumpers



There are two zero-ohm resistors (SMD jumpers): **PWR SEL** is used to determine whether 5V or 3.3V power supply is used, and **REFERENCE** to select either VCC or 4.096V as the voltage reference.

## 7. Code Examples

Once you have done all the necessary preparations, it's time to get your click board up and running. We have provided the examples for mikroC, mikroBasic and mikroPascal compilers on our **Libstock** website. Just download them and you are ready to start.



## 8. Support

MikroElektronika offers **Free Tech Support** ([www.mikroe.com/esupport](http://www.mikroe.com/esupport)) until the end of product lifetime, so if something goes wrong, we are ready and willing to help!