

# EasyMP3™

Manual

*All Mikroelektronika's development systems feature a large number of peripheral modules expanding microcontroller's range of application and making the process of program testing easier. In addition to these modules, it is also possible to use numerous additional modules linked to the development system through the I/O port connectors. Some of these additional modules can operate as stand-alone devices without being connected to the microcontroller.*

Additional board

 **MikroElektronika**

SOFTWARE AND HARDWARE SOLUTIONS FOR EMBEDDED WORLD ...making it simple

## EasyMP3 Additional Board

The *EasyMP3* additional board is used to convert mp3 files into an audio signal by using the VS1011E audio decoder. This signal is reproduced by using headphones connected to CN2 and CN3 connectors. The additional board communicates with the microcontroller via the Serial Peripheral Interface (SPI). The additional board is connected to a development system via a proto board. It is connected to the development system's port linked to the SPI communication module within the microcontroller.

A 1x11 male connector is used to connect the additional board to the microcontroller by using a proto board

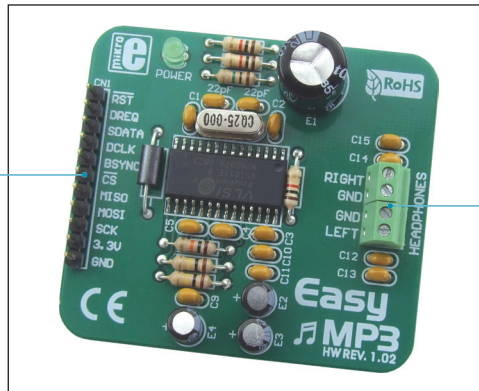

Figure 1: *EasyMP3* additional board

The function of the 1x11 CN1 connector pins:

- |       |                          |      |                                   |
|-------|--------------------------|------|-----------------------------------|
| RST#  | - Audio decoder reset    | CS#  | - Chip selection input (SPI)      |
| DREQ  | - Receive data request   | MISO | - Master input slave output (SPI) |
| SDATA | - Serial input           | MOSI | - Master output slave input (SPI) |
| DCLK  | - Receive data clock     | SCK  | - Serial clock (SPI)              |
| BSYNC | - Synchronization signal |      |                                   |

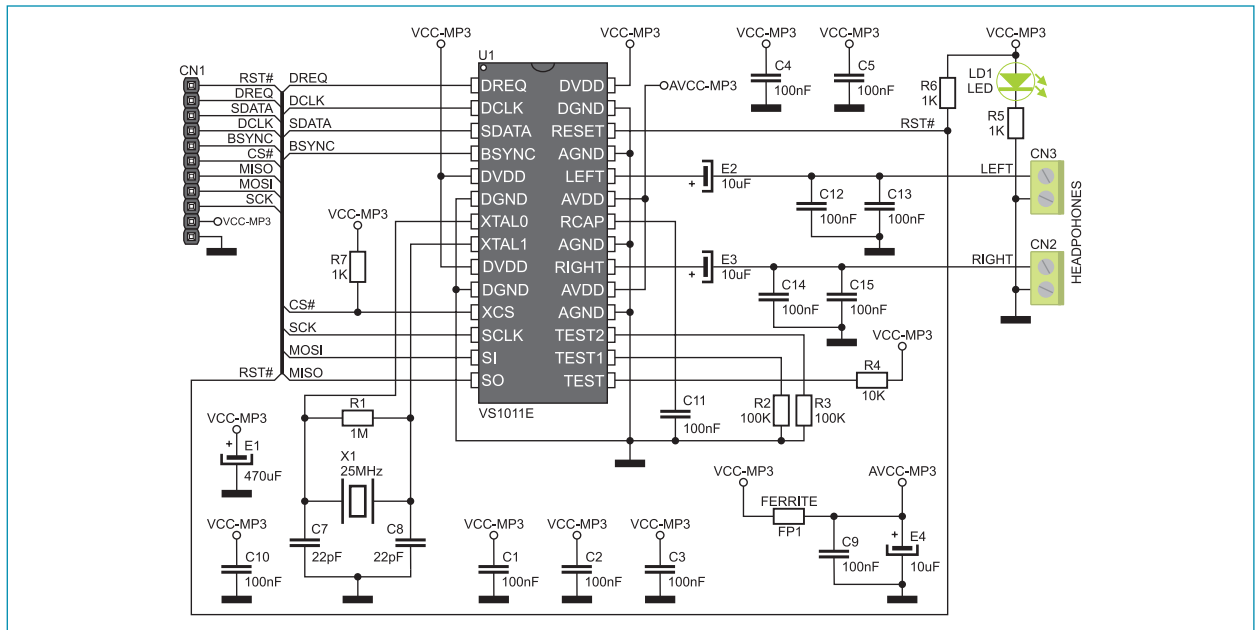

Figure 2: *EasyMP3* additional board connection schematic