

# OK. Now you need a... CAN bus

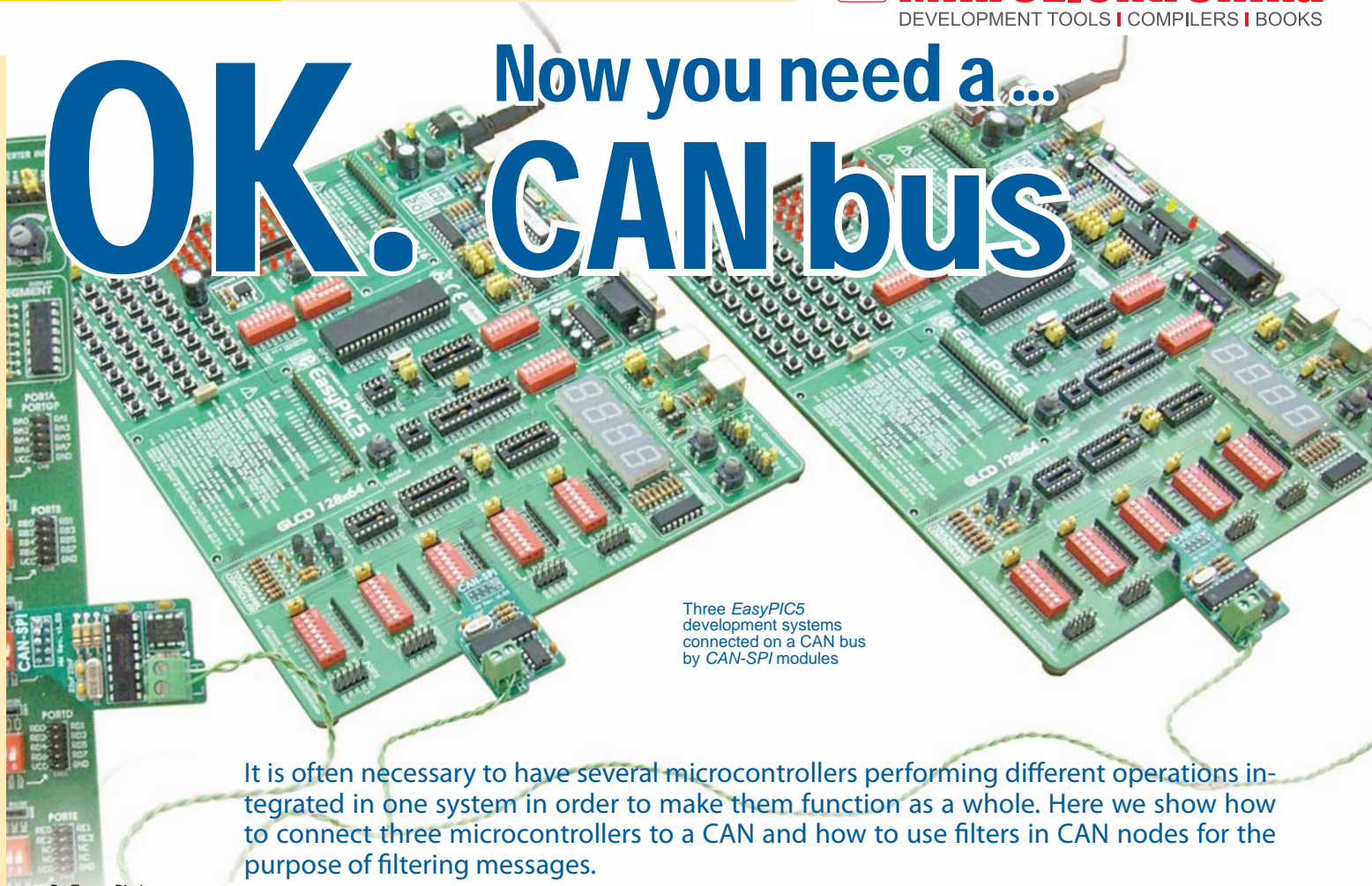

Three EasyPIC5 development systems connected on a CAN bus by CAN-SPI modules

It is often necessary to have several microcontrollers performing different operations integrated in one system in order to make them function as a whole. Here we show how to connect three microcontrollers to a CAN and how to use filters in CAN nodes for the purpose of filtering messages.

By Zoran Ristic  
MikroElektronika - Software Department

Whenever several peripheral units share the same data bus, it is necessary to define how the bus is accessed. The CAN protocol accurately describes all the details on connecting several devices to a network and as such it is widely used in the industry. The protocol primarily defines the precedence of bus implementation and solves the problem of 'collision' within the hardware in the event that several peripheral units start to communicate at the same time.

## Hardware

In this example, a CAN bus will be configured so that the first device sends messages consisting of 0x10 and 0x11 as their ID, while the second and third device send messages consisting of IDs 0x12 and 0x13, respectively. We will also configure the CAN nodes so that the second node responds to incoming messages containing ID 0x10 only, while the third one responds only to those containing the 0x11 ID. Accordingly, the first device is configured to receive messages containing a 0x12 and 0x13 ID (Figure 2). Message filtering is easily implemented by calling the CANSPISetFilter routine which will also handle all the necessary settings of the microcontroller registers and CAN SPI board.

In general, the CAN protocol doesn't require a Master device to be present on the bus. However, to make this example easy to understand while still keeping it general-purpose, we will set the first device only, to initiate communication on the network and another two devices to respond to individual calls.

## Software

When sending a message, the Master node leaves enough time for the called node to respond. In the event that a remote node doesn't respond within the time required, the Master reports an error in the current message and proceeds with calling other nodes (Figure 3). In the event that a peripheral CAN node responds at the same time as another node, a 'collision' will occur on the CAN bus. However, the device address prior-

ity and CAN alone prescribe that in this case the node transmitting the lower priority message withdraws from the bus, thus enabling the node transmitting the higher priority message to proceed with transmission immediately. As mentioned before, we will use an internal SPI module of the microcontroller to transfer data onto the CAN bus. Some of the advantages of using the microcontroller's internal SPI module are: the possibility of generating an interrupt when sending and receiving data; the SPI module operates independently of other peripherals and has a simple configuration. The CAN SPI library enables you to set the operating mode of the CAN and node filters, read data from the CAN SPI board buffer, etc.

This example also includes LEDs on the microcontroller pins indicating that the

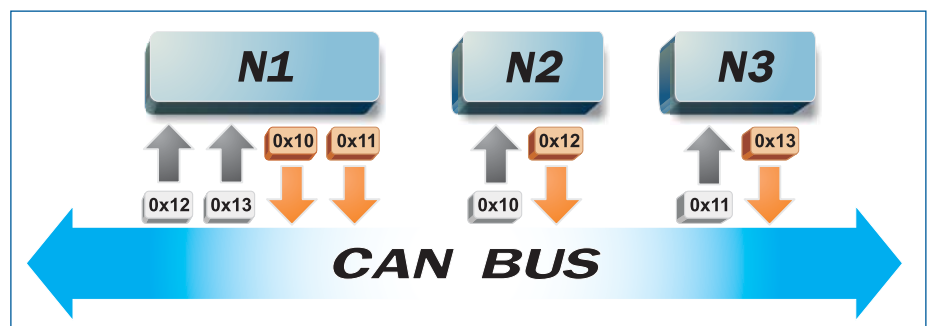
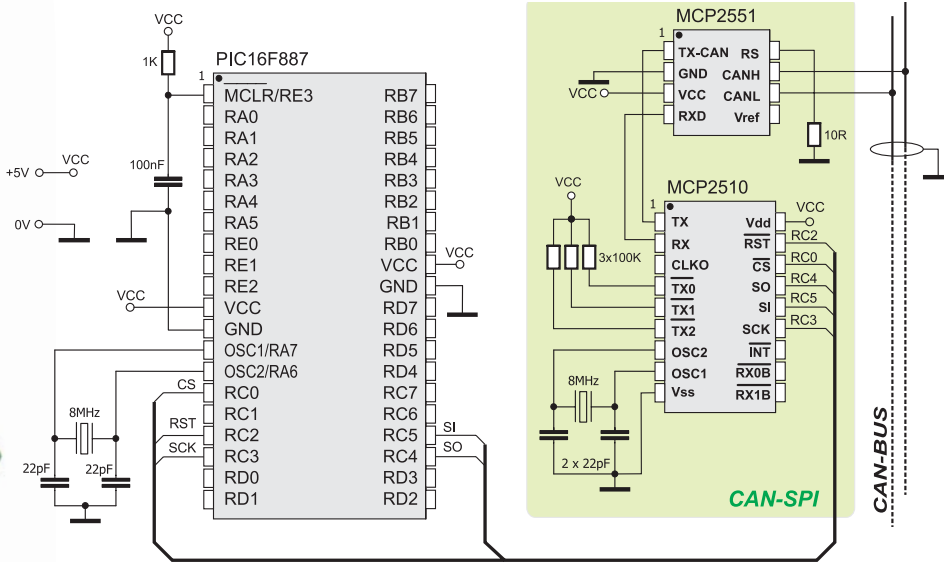

Figure 1. Message filtering



Schematic 1. Connecting the CAN-SPI module to a PIC16F887

Program to demonstrate the operation of a CAN bus

```

program CanSPI
'Description: This program demonstrates how to make a CAN network
using mikroElektronika
' CANSPI boards and mikroBasic compiler.
' Target device: Microchip PIC 16F887
' Oscillator: 8MHz crystal
#DEFINE NODE1 'uncomment this line to build HEX for Node 1
#DEFINE NODE2 'uncomment this line to build HEX for Node 2
#DEFINE NODE3 'uncomment this line to build HEX for Node 3
dim Can_Init_Flags, Can_Send_Flags, Can_Rcv_Flags as byte ' can flags
Rx_Data_Len as byte ' received data length in bytes
Rxtx_Data as byte[8] ' can rx/tx data buffer
Msg_Rcvd as byte ' reception flag
Tx_ID, Rx_ID as longint ' can rx and tx ID
ErrorCount as byte
' CANSPI module connections
dim CanSpi_CS as sbit at RC0_bit ' Chip select (CS) pin for
CANSPI board
CanSpi_CS_Direction as sbit at TRISC0_bit ' Direction register for
CS pin
CanSpi_Rst as sbit at RC2_bit ' Reset pin for CANSPI board
CanSpi_Rst_Direction as sbit at TRISC2_bit
Direction register for Reset pin
' End CANSPI module connections
main:
ANSEL = 0 ANSEHL = 0 ' Configure analog pins as digital I/O
PORTB = 0 TRISB = 0 ' Initialize ports
PORTD = 0 TRISD = 0
ErrorCount = 0 ' Error flag
Can_Init_Flags = 0 Can_Send_Flags = 0 Can_Rcv_Flags = 0 ' clear
flags
Can_Send_Flags = _CANSPI_TX_PRIORITY_0 and ' form value to be used
_CANSPI_TX_XTD_FRAME and ' with CANSPIwrite
_CANSPI_TX_NO_RTR_FRAME
Can_Init_Flags = _CANSPI_CONFIG_SAMPLE_THRICE and ' form value to be used
_CANSPI_CONFIG_PHSRG2_PRG_ON and ' with CANSPIinit
_CANSPI_CONFIG_XTD_MSG and
_CANSPI_CONFIG_DBL_BUFFER_ON and
_CANSPI_CONFIG_VALID_XTD_MSG
SPI_Init() ' initialize SPI module
CANSPIInitialize(1, 3, 3, 1, Can_Init_Flags) ' Initialize external
CANSPI module
CANSPISetOperationMode(CANSPI_MODE_CONFIG, TRUE) ' set CONFIGURATION
mode
CANSPISetMask(_CANSPI_MASK_B1, -1, _CANSPI_CONFIG_XTD_MSG) ' set all
mask1 bits to ones
CANSPISetMask(_CANSPI_MASK_B2, -1, _CANSPI_CONFIG_XTD_MSG) ' set all
mask2 bits to ones
#IFDEF NODE1
CANSPISetFilter(_CANSPI_FILTER_B2_F4, 0x12, _CANSPI_CONFIG_XTD_MSG) '
Node1 accepts messages with ID 0x12
CANSPISetFilter(_CANSPI_FILTER_B1_F1, 0x13, _CANSPI_CONFIG_XTD_MSG) '
Node1 accepts messages with ID 0x13
#ELSE
CANSPISetFilter(_CANSPI_FILTER_B2_F2, 0x10, _CANSPI_CONFIG_XTD_MSG) '
Node2 and Node3 accept messages with ID 0x10
CANSPISetFilter(_CANSPI_FILTER_B1_F2, 0x11, _CANSPI_CONFIG_XTD_MSG) '
Node2 and Node3 accept messages with ID 0x11
#ENDIF
CANSPISetOperationMode(CANSPI_MODE_NORMAL, 0xF) ' set NORMAL mode
RXTX_Data[0] = 0x40 ' set initial data to be sent
#IFDEF NODE1
Tx_ID = 0x10 ' set transmit ID for CAN message
#ENDIF
#IFDEF NODE2
Tx_ID = 0x12 ' set transmit ID for CAN message
#ENDIF
#IFDEF NODE3
Tx_ID = 0x13 ' set transmit ID for CAN message
#ENDIF
#IFDEF NODE1
CANSPIwrite(Tx_ID, RXTX_Data, 1, Can_Send_Flags) ' Node1 sends
initial message
#ENDIF
while (TRUE) ' endless loop
Msg_Rcvd = CANSPIread(Rx_ID, RXTX_Data, Rx_Data_Len, Can_Rcv_Flags)
' attempt receive message
if (Msg_Rcvd) then ' if message is received then check id
#IFDEF NODE1
if Rx_ID = 0x12 then ' check ID
PORTB = RXTX_Data[0] ' output data at PORTB
else
PORTD = RXTX_Data[0] ' output data at PORTD
end if
delay_ms(50) ' wait for a while between messages
CANSPIwrite(Tx_ID, RXTX_Data, 1, Can_Send_Flags) ' send
one byte of data
inc(Tx_ID) ' switch to next message
if Tx_ID > 0x11 then Tx_ID = 0x10 end if ' check overflow
#ENDIF
#IFDEF NODE2
if Rx_ID = 0x10 then begin ' check if this is our message
PORTB = RXTX_Data[0] ' display incoming data on PORTB
RXTX_Data[0] = RXTX_Data[0] shr 1 ' prepare data for
sending back
if RXTX_Data[0] = 0 then RXTX_Data[0] = 1 end if '
reinitialize if maximum reached
delay_ms(10) ' wait for a while
CANSPIwrite(Tx_ID, RXTX_Data, 1, Can_Send_Flags) ' send
one byte of data back
end if
#ENDIF
#IFDEF NODE3
if Rx_ID = 0x11 then ' check if this is our message
PORTD = RXTX_Data[0] ' display incoming data on PORTD
RXTX_Data[0] = RXTX_Data[0] shr 1 ' prepare data for sending
back
if RXTX_Data[0] = 0 then RXTX_Data[0] = 128 end if '
reinitialize if maximum reached
delay_ms(10) ' wait for a while
CANSPIwrite(Tx_ID, RXTX_Data, 1, Can_Send_Flags) ' send
one byte of data back
end if
#ENDIF
else ' an error occurred, wait for a while
#IFDEF NODE1
inc(ErrorCount) ' increment error indicator
delay_ms(10) ' wait for 100ms
if (ErrorCount > 10) then ' timeout: expired - process errors
ErrorCount = 0 ' reset error counter
inc(Tx_ID) ' switch to another message
if Tx_ID > 0x11 then Tx_ID = 0x10 end if ' check overflow
CANSPIwrite(Tx_ID, RXTX_Data, 1, Can_Send_Flags) ' send
new message
end if
#ENDIF
end if
wend
end.
    
```

network operates properly. When node 2 responds to node 1's call, the PORTB LEDs will be automatically turned on. If node 3 responds to the call, the PORTD LEDs will be turned on. The source code for all three nodes in the network is provided with this example. In order to create a HEX file for each of these nodes individually, it is necessary to write only one DEFINE directive in the example header.

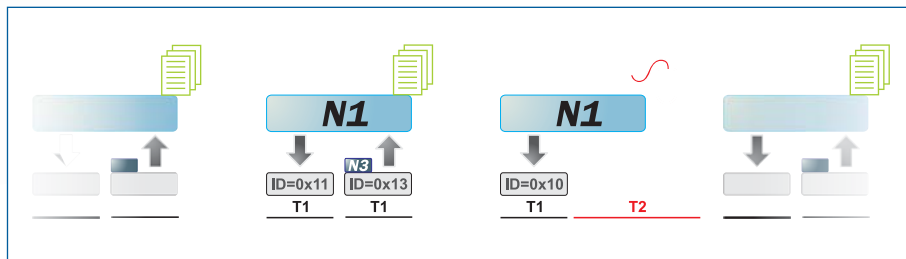

Figure 2. Communication example

In summary, here we have described one way of connecting microcontrollers to the CAN bus. We have also described how to detect errors by means of a communication protocol in the event that a remote node doesn't respond as expected, how to filter messages using CAN filters, as well as how to perform communication in general on the CAN bus.

mikroBASIC PRO for PIC® library editor with ready to use libraries such as: CAN\_SPI, GLCD, Ethernet etc.

Functions used in the program

CANSPIGetOperationMode()	Current operation mode
CANSPIInitialize()*	Initialize the CANSPI module
CANISRead()*	Read message
CANSPISetBaudRate()	Set the CANSPI baud rate
CANSPISetFilter()*	Configure message filter
CANSPISetMask()*	Advanced filtering configuration
CANSPISetOperationMode()*	Current operation mode
CANSPIWrite()*	Write message

\* CANSPI library functions used in the program

Other mikroBASIC PRO for PIC functions used in the program:  
 Delay\_us()  
 SPI1\_init()  
 SPI1\_read()

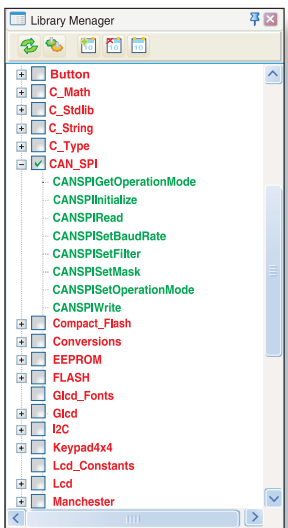

GO TO The program for this example written for PIC® microcontrollers in C, Basic and Pascal as well as the programs written for dsPIC®, 8051 and AVR® microcontrollers may be found on our web site: [www.mikroe.com/en/article/](http://www.mikroe.com/en/article/)

