

# OK. Now you need an ... MP3 player



By Milan Rajic  
MikroElektronika - Software Department

SmartMP3 module connected to  
EasyPIC5 Development System

The use of MP3 format caused a revolution in digital sound compression technology by enabling audio files to be several times smaller. If you want audio messages or music to be part of your project then you can easily make it true. You just need any standard MMC or SD memory card, a few chips and a little time...

Before we start, it is necessary to format MMC card and save the sound1.mp3 file on it (the card should be formatted in FAT16, i.e. FAT format). The quality of sound coded in MP3 format depends on sampling rate and bitrate. Similar to an audio CD, most MP3 files are sampled at the frequency of 44.1 kHz. The MP3 file's bitrate indicates the quality of compressed audio comparing to the original uncompressed one, i.e. its fidelity. A bitrate of 64 kbit/s is sufficient for speech reproduction, while it has to be 128 kbit/s or more for music reproduction. In this example a music file with a bitrate of 128 kbit/s is used.

### Hardware

The sound contained in this file is coded in the MP3 format so that an MP3 decoder is needed for its decoding. In our example, the VS1011E chip is used for this purpose. This chip decodes MP3 record and performs digital-to-analog conversion of the signal in order to produce

a signal that can be brought to audio speakers over a small audio amplifier. Considering that MMC/SD cards use sections of 512 bytes in size, a microcontroller with 512 byte RAM or more is needed for the purpose of controlling the operation of MP3. We have chosen the PIC18F4520 with 1536 byte RAM.

### Software

The program controlling the operation of this device can be broken up into five steps:

- Step 1:** Initialization of the SPI module of the microcontroller.
- Step 2:** Initialization of the compiler's Mmc\_FAT16 library, which enables MP3 files to be read from MMC or SD cards.
- Step 3:** Reading a part of file.
- Step 4:** Sending data to the buffer of MP3 decoder.
- Step 5:** If the end of the file is not reached, jump to step 3.

### Testing

It is recommended to start testing device operation with lower bitrate and increase it gradually. The buffer of MP3 decoder is 2048 bytes in size. If the buffer is loaded with a part of MP3 file with 128 kbit/s bitrate, it will contain twice the sound samples than when it is loaded with a part of file with 256 kbit/s bitrate. Accordingly, if the bitrate of the file is lower it will take twice as long to encode the buffer content. If we over increase the bitrate of the file it may happen that

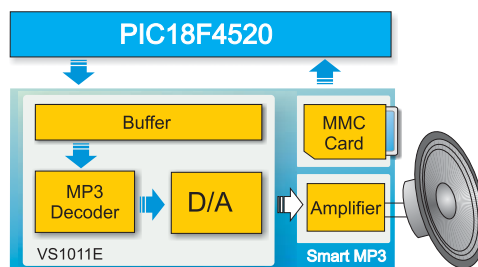
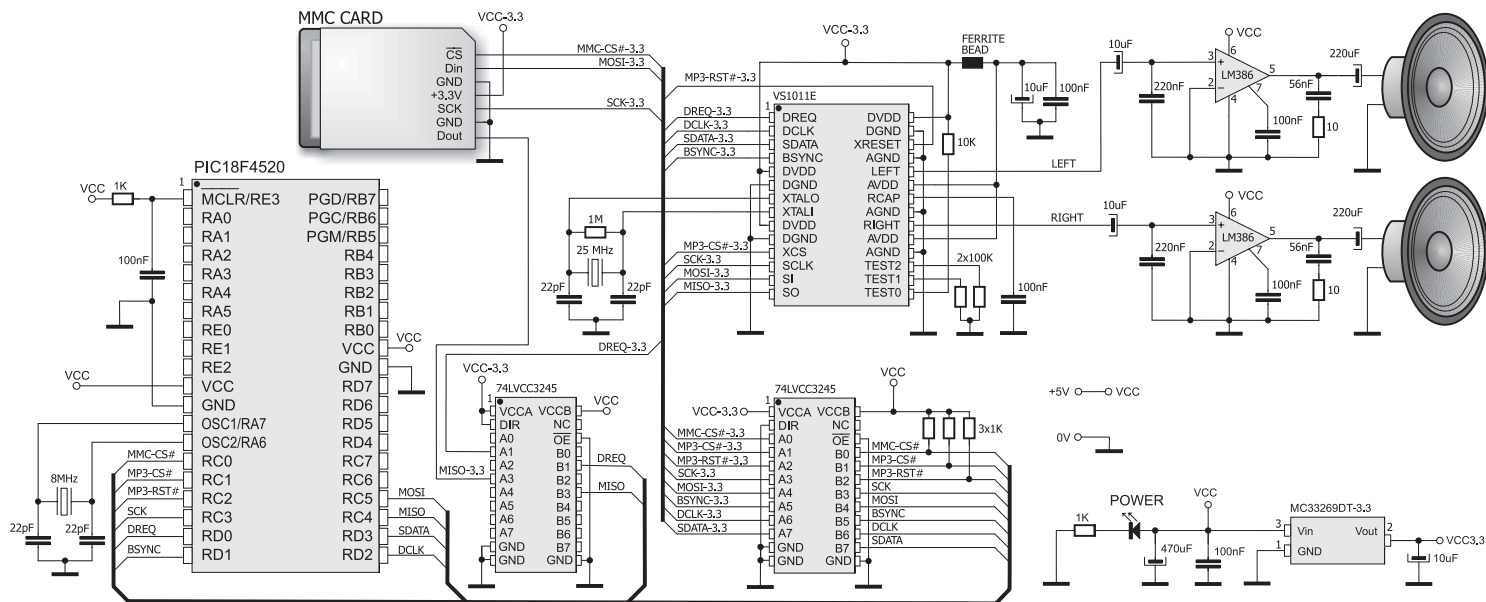

Figure 1. Block diagram of Smart MP3 module connected to a PIC18F4520



Schematic 1. Connecting the Smart MP3 module to a PIC18F4520

buffer content is encoded before the microcontroller manages to read the next part of the file from the card and write it in the buffer, which will cause the sound to be discontinuous. If this happens, we can reduce the MP3 file's bitrate or use a quartz-crystal of frequency higher than 8MHz. Refer to Schematic 1.

Anyway, you don't have to worry about this as our program has been tested on several microcontroller families with different crystal values and it is able to decode MP3 files of average and high quality. On the other hand, a low bitrate means that buffer decoder is filled with sound of longer duration. It may happen that decoder doesn't decode the buffer content before we try to reload it. In order to avoid this, it is necessary to make sure that decoder is ready to receive a new data before it has been sent. In other words, it is necessary to wait until decoder's data request signal (DREQ) is set to logic one (1).

### Enhancements

This example may also be extended after being tested. The DREQ signal can be periodically tested. A routine for volume control or built-in Bass/Treble enhancer control etc. may be included in the program as well. The MMC library enables us to select a file with different name. In this way it is possible to create a set of MP3 messages, sounds or songs to be used in further/other applications and send appropriate MP3 file to the decoder depending on the needs.

Below is a list of ready to use functions contained in the *Mmc FAT16 Library*. This library is integrated in *mikroBASIC for PIC* compiler.

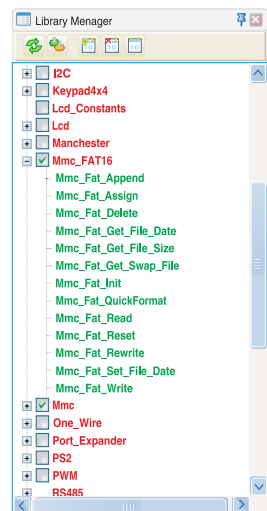

Mmc_Fat_Append()	Write at the end of the file
Mmc_Fat_Assign()*	Assign file for FAT operations
Mmc_Fat_Delete()	Delete file
Mmc_Fat_Get_File_Date()	Get file date and time
Mmc_Fat_Get_File_Size()	Get file size
Mmc_Fat_Get_Swap_File()	Create a swap file
Mmc_Fat_Init()*	Init card for FAT operations
Mmc_Fat_QuickFormat()	
Mmc_Fat_Read()*	Read data from file
Mmc_Fat_Reset()*	Open file for reading
Mmc_Fat_Rewrite()	Open file for writing
Mmc_Fat_Set_File_Date()	Set file date and time
Mmc_Fat_Write()	Write data to file

\* Mmc\_FAT16 functions used in program

Other mikroBASIC for PIC functions used in program:

Spi\_Init\_Advanced() Initialize microcontroller SPI module

Example 1: Program to demonstrate operation of Smart MP3 module

```

program MP3_Simple_Test
const BUFFER_SIZE = 512
dim filename as string[13]
i, file_size as dword
data_buffer_32 as byte[32]
BufferLarge as byte[BUFFER_SIZE]
sub procedure SW_SPI_Write(dim data as byte) 'Writes one byte to MP3 SDI
PORTD.1 = 1 'Set BSYNC before sending the first bit
PORTD.2 = 0 PORTD.3 = data_0 PORTD.2 = 1 'Send data_LSB, data_0
PORTD.2 = 0 PORTD.3 = data_1 PORTD.2 = 1 'Send data_1
PORTD.1 = 0 'Clear BSYNC after sending the second bit
PORTD.2 = 0 PORTD.3 = data_2 PORTD.2 = 1 'Send data_2
PORTD.2 = 0 PORTD.3 = data_3 PORTD.2 = 1 'Send data_3
PORTD.2 = 0 PORTD.3 = data_4 PORTD.2 = 1 'Send data_4
PORTD.2 = 0 PORTD.3 = data_5 PORTD.2 = 1 'Send data_5
PORTD.2 = 0 PORTD.3 = data_6 PORTD.2 = 1 'Send data_6
PORTD.2 = 0 PORTD.3 = data_7 PORTD.2 = 1 'Send data_7
PORTD.2 = 0
end sub
'Writes one word to MP3 SCI
sub procedure MP3_SCI_Write(dim address as byte, dim data_in as word)
PORTC.1 = 0 'select MP3 SCI
SPI_write(0x02) 'send WRITE command
SPI_write(address)
SPI_write(data_in >> 8) 'Send High byte
SPI_write(data_in) 'Send Low byte
PORTC.1 = 1 'deselect MP3 SCI
while (PORTD.0 = 0) nop wend 'wait until DREQ becomes 1, see MP3 codec datasheet,
Serial Protocol for SCI
end sub
'Reads words_count words from MP3 SCI
sub procedure MP3_SCI_Read(dim start_address, words_count as byte, dim data_buffer as
^byte)
dim i as byte
PORTC.1 = 0 'select MP3 SCI
SPI_write(0x03) 'send READ command
SPI_write(start_address)
for i = 1 to (2*words_count)
data_buffer^i = SPI_read(0) 'read words_count words byte per byte
' read and store a byte
point to next byte
next i
PORTC.1 = 1 'deselect MP3 SCI
while (PORTD.0 = 0) nop wend 'wait until DREQ becomes 1, see MP3 codec datasheet,
Serial Protocol for SCI
end sub
sub procedure MP3_SDI_Write(dim data as ^byte) 'Write one byte to MP3 SDI
while (PORTD.0 = 0) nop wend 'wait until DREQ becomes 1, see MP3 codec datasheet,
Serial Protocol for SCI
SW_SPI_Write(data_)
end sub
sub procedure MP3_SDI_Write_32(dim data as ^byte) 'Write 32 bytes to MP3 SDI
dim i as byte
while (PORTD.0 = 0) nop wend 'wait until DREQ becomes 1, see MP3 codec datasheet,
Serial Protocol for SCI
for i = 1 to 32
SW_SPI_Write(data_^i) 'Write byte pointed by data
Inc(data_)
next i
end sub
sub procedure Set_Clock(dim clock_khz as word, dim doubler as byte) 'Set clock
clock_khz = clock_khz / 2 'calculate value
if (doubler > 0) then clock_khz = clock_khz or 0x8000 end if
MP3_SCI_Write(0x03, clock_khz) 'Write value to CLOCKS register
end sub
sub procedure Init()
ADCON1 = ADCON1 or 0x0F 'Configure AN pins as digital
CMCON = CMCON or 7 'Disable comparators
TRISD.2 = 0 TRISD.3 = 0 'Set SW SPI pin directions to output
PORTD.2 = 0 PORTD.3 = 0 'Clear SW SPI SCK and SDO
TRISC.1 = 0 PORTC.1 = 1 'Configure MP3_CS as output and deselect MP3_CS
TRISC.2 = 0 PORTC.2 = 1 'Configure MP3_RST as output and set MP3_RST pin
TRISD.0 = 1 'Configure DREQ as input
TRISD.1 = 0 PORTD.1 = 0 'Configure BSYNC as output and clear BSYNC
end sub
sub procedure Soft_Reset()
MP3_SCI_Write(0x00, 0x204) 'Software Reset
' Set SM_RESET bit and SM_BITORD bit(bitorder is LSB first)
Delay_us(2) 'Required, see MP3 codec datasheet -> Software Reset
while (PORTD.0 = 0) nop wend 'wait until DREQ becomes 1, see MP3 codec datasheet,
Serial Protocol for SCI
for i = 1 to 2048 MP3_SDI_Write(0) next i 'feed 2048 zeros to the MP3 SDI bus
end sub
main:
' main function
filename = "sound1.mp3" ' Set File name
Init()
SPI_init_advanced(MASTER_OSC_DIV64, DATA_SAMPLE_MIDDLE, CLK_IDLE_LOW, LOW_2_High)
Soft_Reset() Set_Clock(25000, 0) 'SW Reset, set clock to 25MHz, do not use clock doubler
if (Mmc_Fat_Assign(filename, 0) = 0) then Assign file "sound1.mp3"
Mmc_Fat_Reset(file_size) ' Call Reset before file reading
while (file_size > BUFFER_SIZE) ' Send file blocks to MP3 SDI
for i = 0 to BUFFER_SIZE - 1
Mmc_Fat_Read(BufferLarge[i]) ' Read file block
next i
for i = 0 to BUFFER_SIZE / 32 - 1 ' Send file block to mp3 decoder
MP3_SDI_Write_32(BufferLarge + i*32)
next i
file_size = file_size - BUFFER_SIZE ' Decrease file size
wend
' send the rest of the file to MP3 SDI
for i = 0 to file_size - 1 Mmc_Fat_Read(BufferLarge[i]) next i
for i = 0 to file_size - 1 MP3_SDI_Write(BufferLarge[i]) next i
end if
end if

```

Written in compiler  
mikroBASIC  
for PIC

GO TO Code for this example written for PIC® microcontrollers in C, Basic and Pascal as well as the programs written for dsPIC® and AVR® microcontrollers can be found on our web site: [www.mikroe.com/en/article/](http://www.mikroe.com/en/article/)